

POST BACKFILL DETAIL

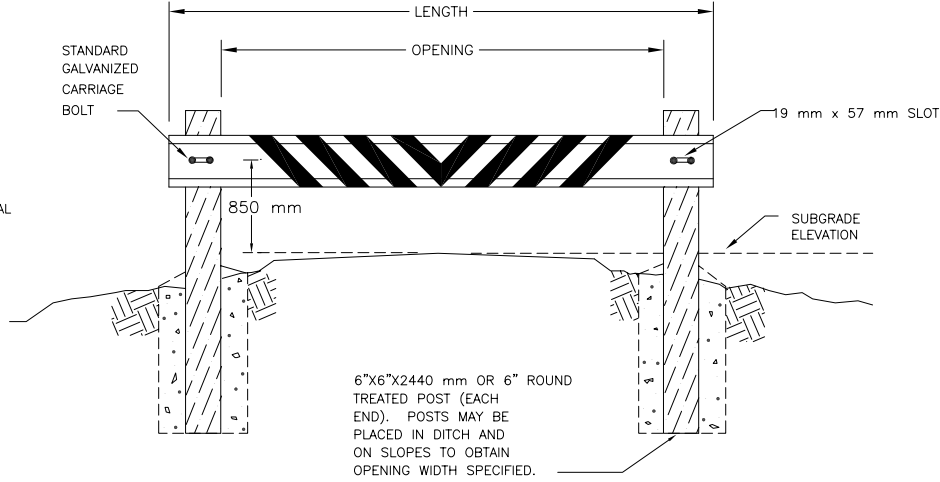

GENERAL NOTES

- POSTS SHALL BE DRESSED, ROUGH, OR WORKED LUMBER, CONFORMING TO THE REQUIREMENTS OF AASHTO DESIGNATION M-168-84. POST SHALL BE STRUCTURAL GRADE NO. 2 OR BETTER, WHEN GRADED ACCORDING TO CURRENT RULES OF EITHER THE WEST COAST LUMBER INSPECTION BUREAU OR WESTERN WOOD PRODUCTS ASSOCIATION. POSTS SHALL BE TREATED IN ACCORDANCE WITH AWPA C-2 USING ONE OF THE FOLLOWING:
  - WATER BORN PRESERVATIVES PER AWPA STANDARD P5 TO A RETENTION OF 6 kg/m<sup>3</sup>.
  - PENTACHLOROPHENOL MEETING AWPA P-8 USING AN AWPA P-9 TYPE A SOLVENT TO A RETENTION OF 6 kg/m<sup>3</sup>.
  - CREOSOTE MEETING AWPA P1/P13 TO A RETENTION OF 130 kg/m<sup>3</sup>.
- DRAWINGS NOT TO SCALE.
- BARRIERS SHALL BE LOCATED AS SHOWN IN THE LOCATION CHART OR AS STAKED ON THE GROUND.
- GUARDRAIL SHALL BE GALVANIZED BEAM-TYPE GUARDRAIL, CLASS A, TYPE 2, MEETING THE REQUIREMENTS OF SECTION 710 OF FOREST SERVICE SPECIFICATIONS FOR CONSTRUCTION OF ROADS AND BRIDGES, 1996. GUARDRAIL AND ALL PARTS WILL BE THOROUGHLY CLEANED PRIOR TO APPLYING ONE COAT OF ZINC CHROMATE PRIME COAT PAINT, FOLLOWED BY APPLYING ONE COAT OF WHITE MACHINERY PAINT. THEN APPLY PRESSURE SENSITIVE REFLECTORIZED "SCOTCHLITE" AS MFG. BY "3M" CO., OR APPROVED EQUAL. ALLOWABLE OPTION IS BRIGHT RED MACHINERY PAINT. APPLY AS SHOWN ABOVE. ANOTHER ALLOWABLE OPTION IS TWO 300 mm X 900 mm STANDARD TYPE 1 BARRICADE RAILS WITH RED AND WHITE STRIPES BOLTED TO GUARDRAIL WITH NUTS WELDED TO PREVENT LOOSENING.

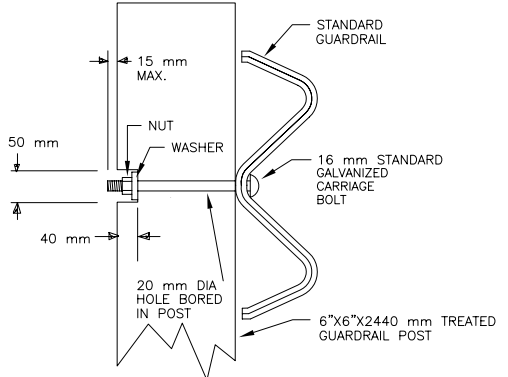

GUARDRAIL ATTACHMENT DETAIL

LENGTH CHART	
OPENING	LENGTH
4.3 m	4.7 m
4.6 m	5 m
4.9 m	5.3 m

LOCATION CHART		
ROAD#	OPENING SIZE	km/STATION

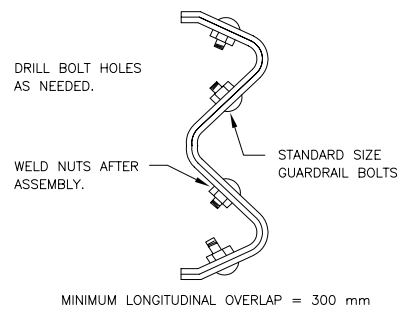

SPLICE DETAIL

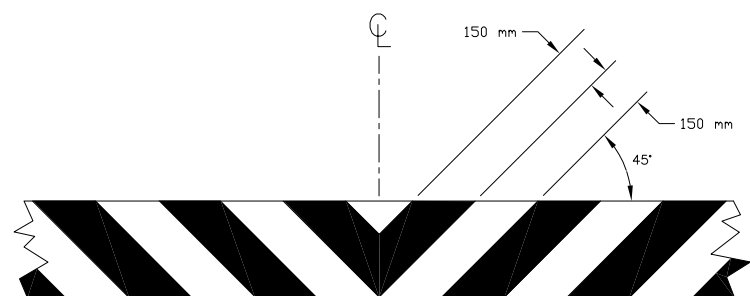

MARKING PLAN

VERSION 1  
5/7/97  
WAW00033.DWG

U.S. DEPARTMENT OF AGRICULTURE  
WALLOWA-WHITMAN NATIONAL FOREST

STANDARD DETAILS FOR GUARDRAIL BARRIER

RECOMMENDED BY: \_\_\_\_\_ DATE: \_\_\_\_\_  
FOREST DEVELOPMENT ENGINEER

APPROVED BY: \_\_\_\_\_ DATE: \_\_\_\_\_  
FOREST ENGINEER